

BACK



**DIESEL ENGINE
SERVICE EQUIPMENT**



DIESEL ENGINE SERVICE EQUIPMENT

DIESEL NOZZLE TESTER



Model	DT-60N	DT-60VN
Attachment	–	Flow Control Valve
Pressure Gauge	MPa	0 – 50
Min. Calibration	MPa	0.98
Fuel Reservoir	cc	600
Overall Length	mm	Approx. 420
Weight	kg	Approx. 5.5
		Approx. 5.7

• Attachment

Model	Form	Applicable Vehicle	Size
DT-60-1		ISUZU	φ 14mm × 1.5
DT-60-2		UD	φ 16mm × 1.5
DT-60-3		ELF, JUPITOR DYNA, CANTER DAIHATSU DE	φ 12mm × 1.5
DT-60-4		TOYOTA RANGER NISSAN SD22 MAZDA WA	φ 12mm × 1.5

DIESEL ENGINE TACHOMETER



Model	DACS-010-5A
Applicable Engine	Bosch Type Injection Pump
Measurable Range	rpm Low: 0 – 1,500 High: 0 – 6,000
Pick Up	To be installed to the section of Injection Pipe Clamping Nut
Electric Source	Battery 6 V and 12V, 2-way
Dimensions (W × H × D)	310 × 200 × 130 mm
Weight	Approx. 3.5 kg

DIESEL TIMING TACHO TESTER



Model	DF-7712
Applicable Engine	2.4-cycle Diesel
Power Source	DC 10 – 32V
Measurement Range	rpm Engine, 120 – 9,990
Indication	LED Twin Digital Display
Sensor	Sleeve-nut method
Dimensions (W × H × D)	300 × 212 × 191 mm
Weight	Approx. 3 kg

DIESEL ENGINE CYLINDER LINER PULLER

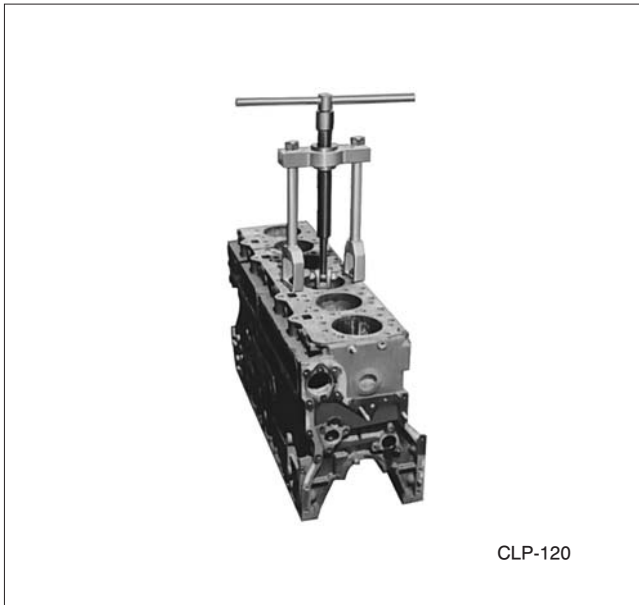

Model	Capacity mm	Note
CLP-75	82 – 150	Wet Type
CLP-120	102, 105, 108, 125, 133, 135	Dry Type
CLP-120-S	For ISUZU, E116, D920, E120	
CLP-120-H	For HINO, EH110, 500, 700	
CLP-120-N	For NISSAN, ND, PD, PE	
CLP-120-M	For MITSUBISHI, 4DR, 6DR, 4D	

• Attachment

Model	Applicable Vehicle	Vehicle Model
1-S	ISUZU	E-120, 6RA
6-S	ISUZU	6-BB
2-N	NISSAN	PE-6
3-N	NISSAN	PD-6
4-H	HINO	EH-500
5-H	HINO	EH-100, HO-6

COMPRESSION GAUGE (FOR DIESEL ENGINE)



• DG-8S Standard Accessories

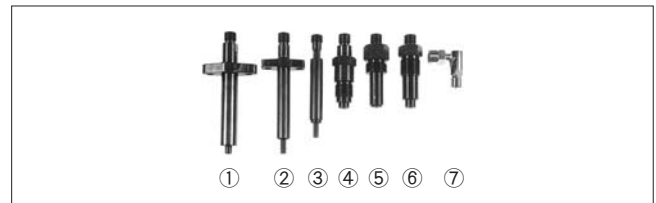

No.	Model	
①	i-5DG	ISUZU, 6BB-1, 6BA-1, 4BA-1, 6BD-1
②	T-4DG	TOYOTA, DYNA
③	F-11DG	FUSO, 4D-31
④	T-2DG	TOYOTA, J, 2J, HBQ
⑤	F-3DG	FUSO, 6DS, 6DB, 6DC, 8DB, 8DC
⑥	i-3DG	ISUZU, ELF, C221, C240, TLD-24
⑦	L-1DG	L-type joint

• DG-8L Standard Accessories

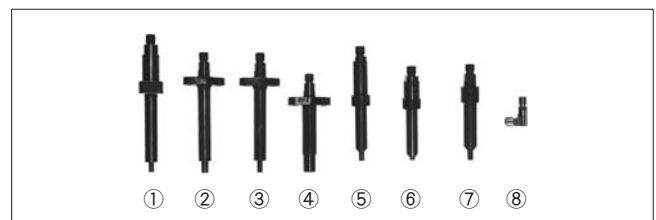

No.	Model	
①	i-4DG	ISUZU, E-120
②	F-7DG	FUSO
③	F-8DG	FUSO, 6D
④	N-2DG	NISSAN, PD
⑤	H-4DG	HINO, ED
⑥	H-5DG	HINO, EF
⑦	i-7DG	ISUZU, PA
⑧	L-1DG	L-type joint

Model		DG-8S	DG-8L
Application		Medium Cars	Large Vehicles
Range	MPa	0 – 6.86	0 – 6.86
Case Size	mm	335 × 230 × 60	370 × 280 × 60
Weight approx.	kg	3.8	6.2

- As for adapter which are not shown on this catalog please contact.

FUEL CONSUMPTION METER FOR DIESEL



- For Pass. Cars Light Truck

Model	DE-S	
Battery		DC 12V
Fuel Flow	ℓ /h	1 – 40
Digital Reading		Max. 999.99 ℓ Min. 10cc
Case Size (W × H × D)	mm	240 × 215 × 90
Weight	kg	3.5



- For Large Vehicles

Model	DE-FL	
Battery		DC 24V
Fuel Flow	ℓ /h	5 – 200
Digital Reading		Max. 999.99 ℓ Min. 10cc
Case Size (W × H × D)	mm	300 × 200 × 100
Weight	kg	4.5



- Both Diesel Engine and Gas. Engine

Model	DE-S-G2	
Battery		DC-12V
Fuel Flow	ℓ /h	for Gasoline 2 – 40 for Diesel 1 – 40
Digital Reading		Max. 999.99 ℓ Min. 10cc
Case Size (W × H × D)	mm	360 × 240 × 130
Weight	kg	6.2